

Product data

Features

- Differential inductive sensing principle
- Insensitive to magnetic interference fields
- Robust against oil, water, dust, particles
- Ultra-thin package, 0.9 mm thick
- Pads for surface-mount soldering of cable
- Thin and low-cost PCB-type target strips/discs

Applications

- Brushed and brushless motors
- Industrial / laboratory / office automation
- Linear stages and X-Y tables
- Assembly / Pick & Place equipment
- Linear motor, voice coil actuator
- Pneumatic/hydraulic actuator

General Specifications

Output format.....A quad B
 Phase shift..... $90 \pm 45^\circ$
 Duty cycle..... $50 \pm 25\%$
 Index length..... 90° (A and B high h)
 Resolution.....0.3 - 150 μm , adjustable
 Maximum speed.....0.05 – 50 m/s, adjustable
 Airgap.....up to 1 mm, see Table 1
 Supply..... $5.0 \pm 0.5 \text{ V}$, 25 mA typ
 Temperature.....0 – 100°C
 Target material.....Copper on FR4
 Nominal target period.....1.2 mm

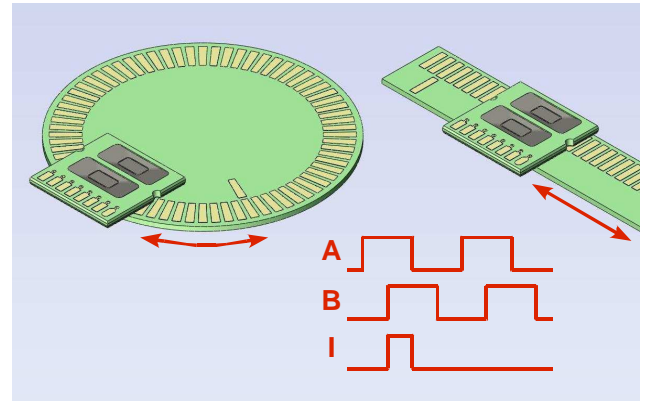

Description

The IT3401 encoder kit consists of a sensor element and a PCB-type target. The triple-channel sensor-element provides incremental A and B output signals in quadrature and an Index signal. The target is either a strip for linear applications or a disc/ring for rotational applications.

The maximum interpolation factor that can be adjusted depends on the Signal to Noise Ratio (SNR). The noise depends on the bandwidth and thus on the maximum speed. The signal depends on the distance between sensor and target (the signal increases exponentially when the airgap is reduced). The resolution, maximum speed and the airgap are thus dependent on each other, as shown in Table 1.

Table 1 Maximum airgap as a function of resolution and maximum speed.

Res/period	Max speed (target periods/second)									
		Bits	Pulse	10	39	156	625	2.5k	10k	40k
3	2	0.8	0.8	0.8	0.8	0.7	0.7	0.7	0.7	0.7
4	4	0.8	0.8	0.8	0.8	0.7	0.7	0.5	0.3	0.3
5	8	0.8	0.8	0.8	0.7	0.7	0.5	0.3	0.1	-
6	16	0.8	0.7	0.7	0.7	0.5	0.3	0.1	-	-
7	32	0.7	0.7	0.5	0.5	0.3	0.1	-	-	-
8	64	0.5	0.5	0.3	0.3	0.1	-	-	-	-
10	256	0.3	0.3	0.3	0.1	-	-	-	-	-
11	512	0.3	0.3	0.1	-	-	-	-	-	-
12	1024	0.1	0.1	-	-	-	-	-	-	-

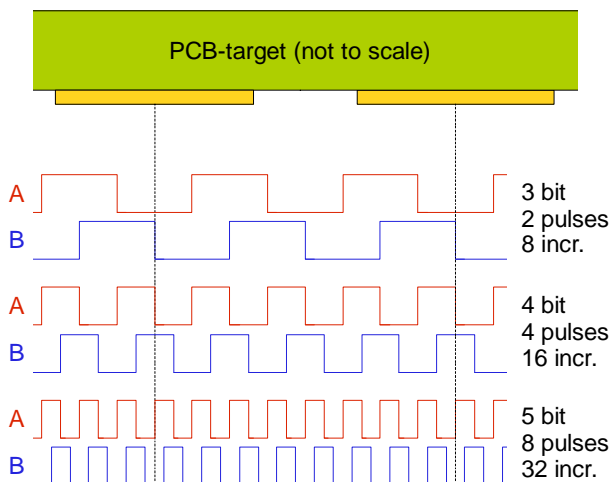
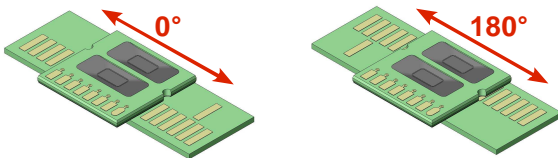

Fig. 1 A quad B signals over one period of 1.2 mm with interpolation 3 – 5 bit.

Ordering information

Ordering code: IT3401-ABCC
 Please note that the combination of speed (BB) and resolution (CC) must be an existing combination according to Table 1 (colored case).

A	Orientation	Outputs
0	0°	A2, B2, I2
2	180°	A1, B1, I1



BB	Speed (target periods/second)		
00	10 Hz	07	1.25 kHz
01	20 Hz	08	2.5 kHz
02	39 Hz	09	5 kHz
03	78 Hz	10	10 kHz
04	156 Hz	11	20 kHz
05	313 Hz	12	40 kHz
06	625 Hz		

CC	Resolution per target-period			
	Linear	Bits	Pulses	Incr.*
03	150 μm	3	2	8
04	75 μm	4	4	16
05	37.5 μm	5	8	32
06	18.8 μm	6	16	64
07	9.4 μm	7	32	128
08	4.7 μm	8	64	256
10	1.2 μm	10	256	1024
11	0.6 μm	11	512	2048
12	0.3 μm	12	1024	4096

* One increment corresponds to the distance between two adjacent A-B transitions.

Linear and rotational targets

Linear and rotational targets are available from POSIC.

Evaluation kit

The evaluation kit for the IT3401 sensor contains one Sensor Evaluation Board, a linear and/or rotational target and two IT3401-ABCC sensors.

Detailed information on the Evaluation Kit for incremental applications can be downloaded from POSIC's website www.posic.com.

Sensor and target customization.

Customization of sensors and/or targets for a specific application is offered as an engineering service by POSIC.

Technical drawing

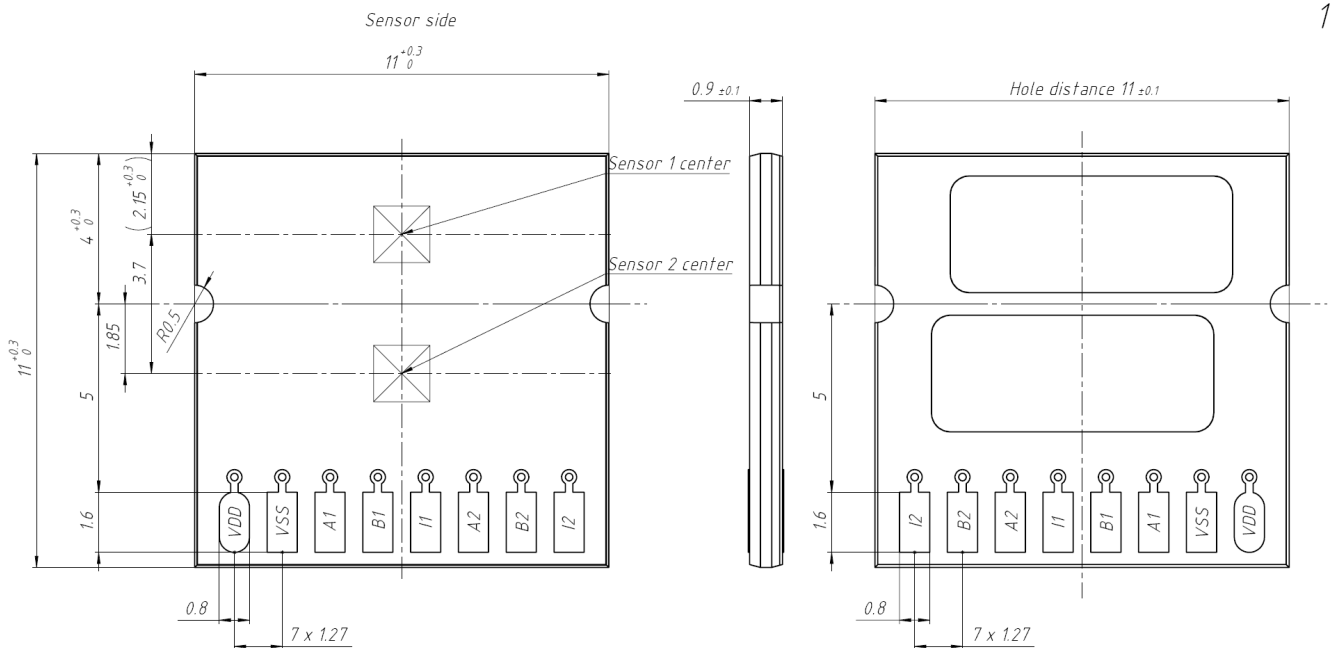

Data subject to change without notice. The information in this document is of preliminary nature, no responsibility is assumed by POSIC for its use, nor for infringements of patents or other rights of third parties which may result from its use. No license is granted by implication or otherwise under any patent or patent rights of POSIC.